

ITEM:	MATERIAL:	FINISH:	NOTES:
CONNECTOR BODY	BRASS, NOTE 1	NICKEL, NOTE 9	1. PER QQ-B-626 2. PER QQ-S-764 3. PER QQ-C-530 4. PER QQ-B-750 5. PER MIL-P-19468 6. PER ZZ-R-765 7. PER WW-T-799 8. GOLD PLATED 5µin MIN. OVER NICKEL PLATE 50µin MIN. OVER COPPER STRIKE. 9. NICKEL PLATE 100µin MIN. OVER COPPER STRIKE. 10. PER ASTM-A967 11. GOLD PLATE 30µin MIN. OVER NICKEL PLATE 50µin MIN. OVER COPPER STRIKE. 12. TIN ZINC PLATE 100µin MIN. OVER COPPER STRIKE.
CENTER CONTACT	BRASS, NOTE 1	GOLD, NOTE 8	
INSULATION	TEFLON, NOTE 5	-----	
FERRULE	BRASS, NOTE 1	NICKEL, NOTE 9	
GASKET	SILICONE RUBBER, NOTE 6	-----	
HEX NUT	BRASS, NOTE 1	NICKEL, NOTE 9	
LOCK WASHER	BRASS, NOTE 1	NICKEL, NOTE 9	

REVISIONS				
REV	ECR	DESCRIPTION	DRAWN	DATE
1		ENGINEERING RELEASE	M. LARSEN	05/01/2023

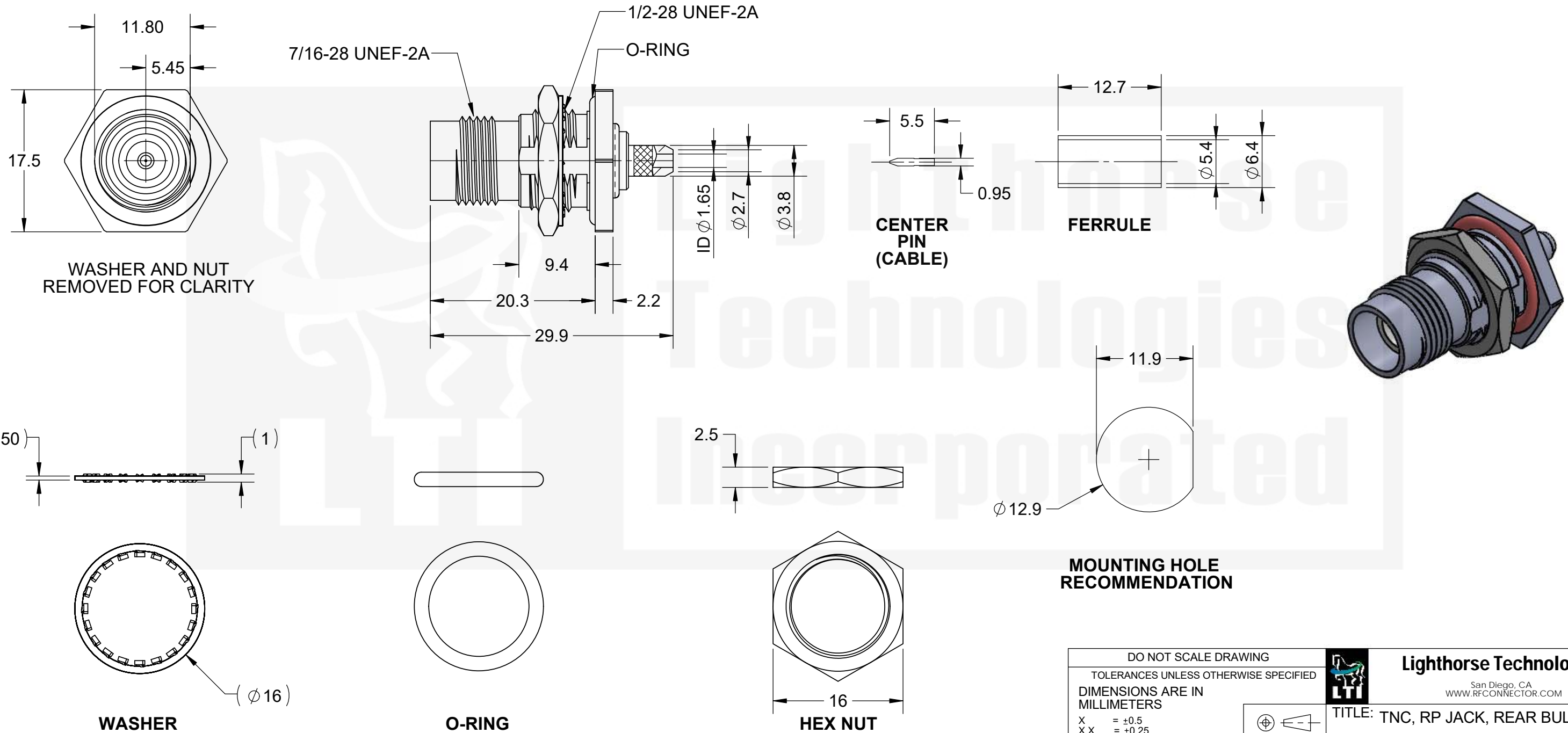

PROPRIETARY AND CONFIDENTIAL
 UNLESS OTHERWISE SPECIFIED: THIS DOCUMENT CONTAINS LIGHORSE TECHNOLOGIES INFORMATION. REPRODUCTION, USE, DISCLOSURE OR TRANSMITTAL OF ALL OR ANY PART OF THIS DOCUMENT IS PROHIBITED EXCEPT TO THE EXTENT APPROVED IN WRITING BY AN AUTHORIZED REPRESENTATIVE OF LIGHORSE TECHNOLOGIES. LIGHORSE TECHNOLOGIES RESERVES ALL RIGHTS UNDER PATENTS, TRADEMARKS, COPY RIGHTS AND TRADE SECRETS. COPY RIGHTS OF LIGHORSE TECHNOLOGIES 2011, ALL RIGHTS RESERVED.



DO NOT SCALE DRAWING
 TOLERANCES UNLESS OTHERWISE SPECIFIED
 DIMENSIONS ARE IN MILLIMETERS
 X = ±0.5
 X.X = ±0.25
 X.XX = ±0.13
 ANGLE = ±30'

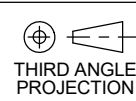

Lighthouse Technologies
 San Diego, CA
 WWW.RFCONNECTOR.COM

TITLE: TNC, RP JACK, REAR BULKHEAD, CABLE CRIMP, ISOLATED
 IP-67 RATED, INTERNAL SEALS

CUSTOMER APPROVAL	
SIGN / DATE:	
ENG APPR.	
CHECKED	
DRAWN	M. LARSEN
NAME	DATE

SIZE	PART/DWG. NO:	REV
B	TSRF13RENT-316	1
SCALE: 2:1	FILE NAME	SHEET 1 OF 1